

RE·BAR·TIER

RB441T(CE) RB611T(CE)

INSTRUCTION MANUAL AND SAFETY INSTRUCTIONS

TWINTIER



RB441T(CE)



RB611T(CE)

INDEX

ENGLISH

Page

2

to

19



WARNING

Before using the tool, read and understand tool labels and manual. Failure to follow warnings could result in serious injury. Keep these instructions with the tool for future reference.

Fig.1

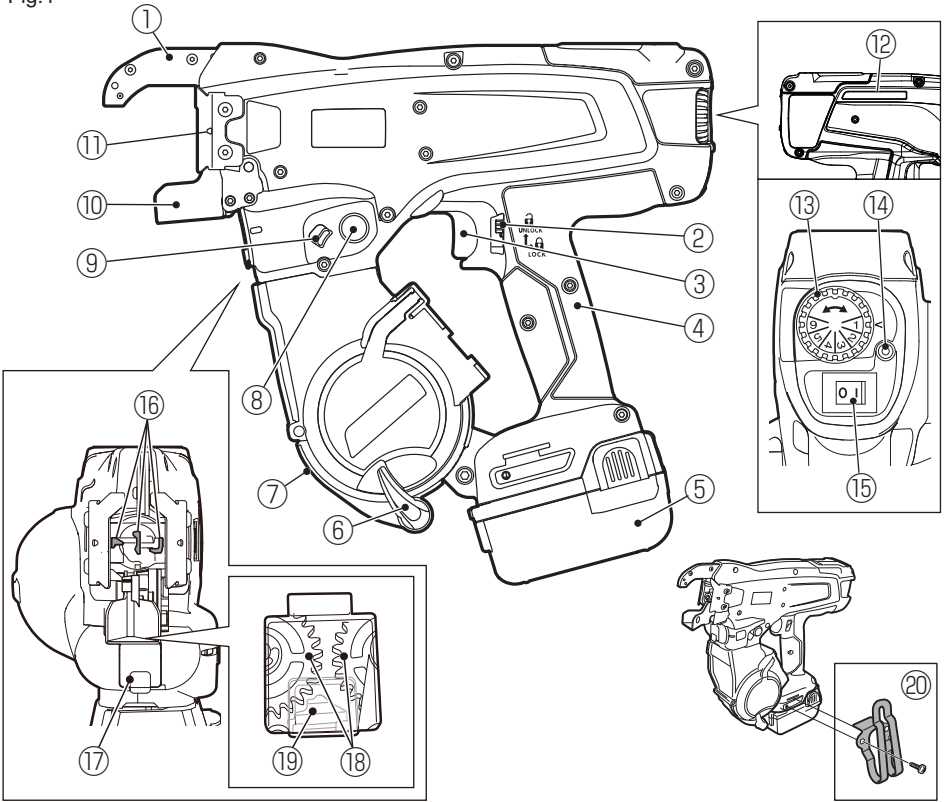

Fig.2

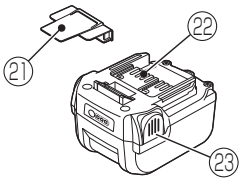

Fig.3

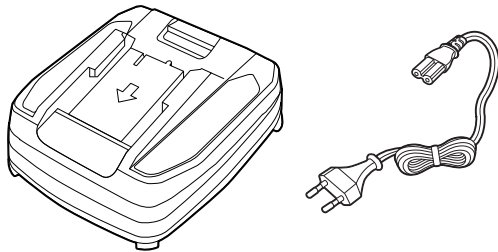

Fig.4

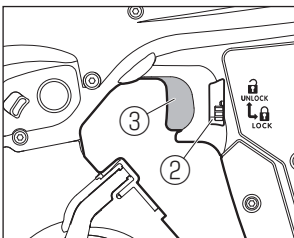

Fig.5

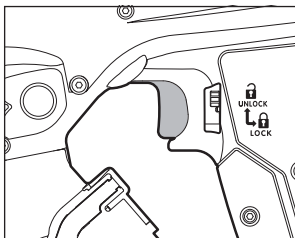

Fig.6

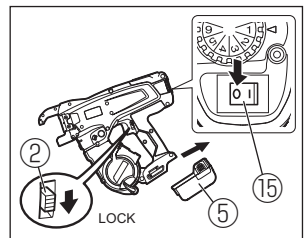

Fig.7

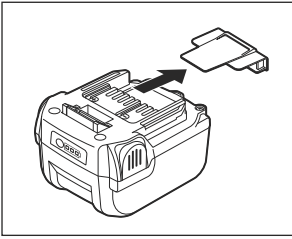

Fig.8

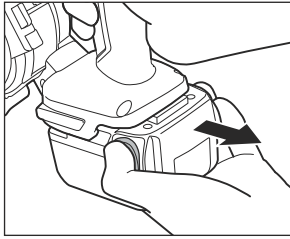

Fig.9

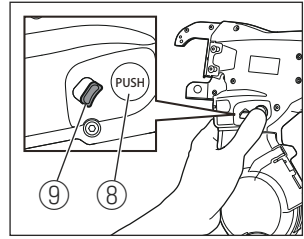

Fig.10

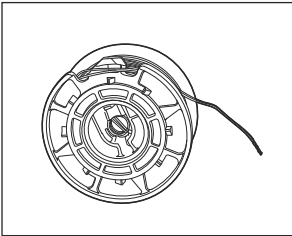

Fig.11

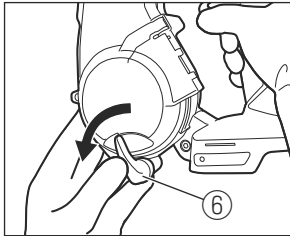

Fig.12

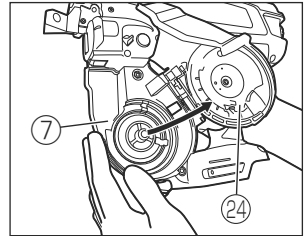

Fig.13

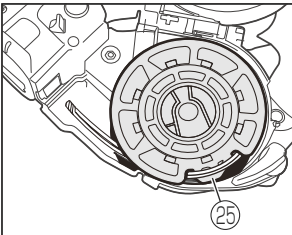

Fig.14

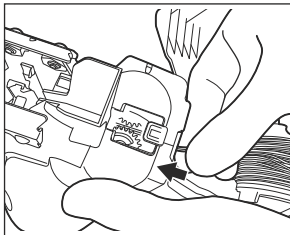

Fig.15

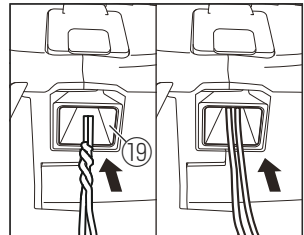

Fig.16

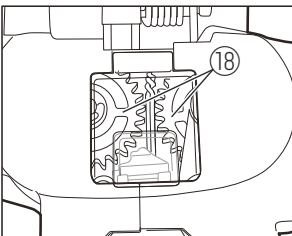

Fig.17

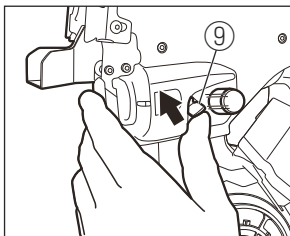

Fig.18

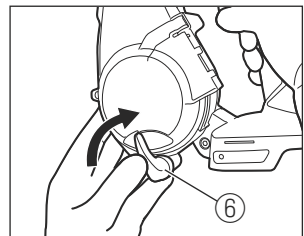

Fig.19

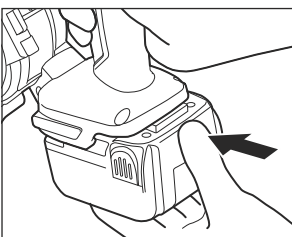

Fig.20

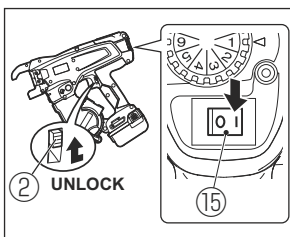

Fig.21

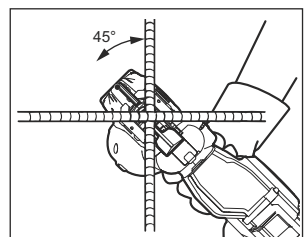

Fig.22

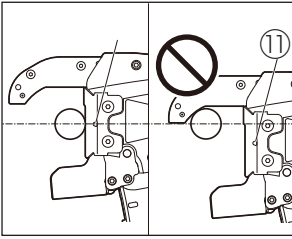

Fig.23

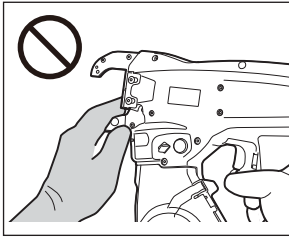

Fig.24

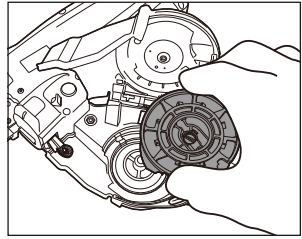

Fig.25

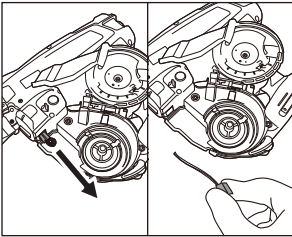

Fig.26

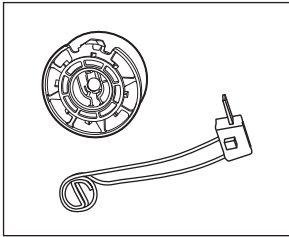

Fig.27

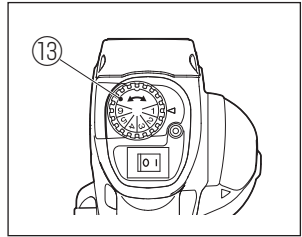

Fig.28

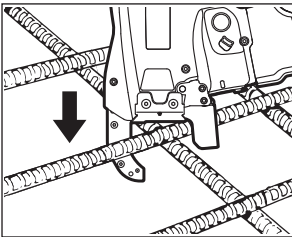

Fig.29

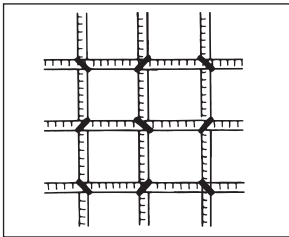

Fig.30

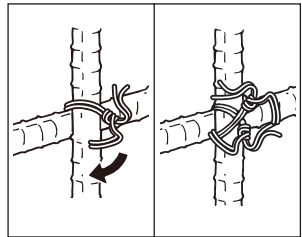

Fig.31



Fig.32

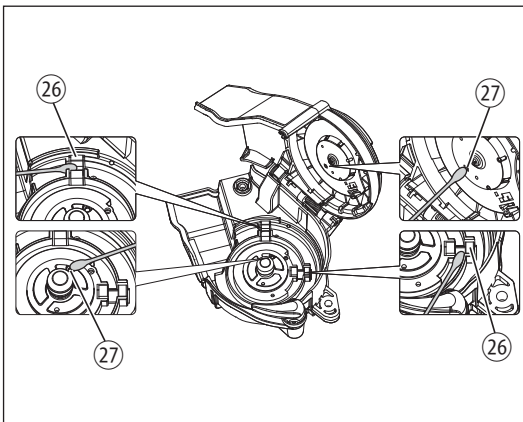
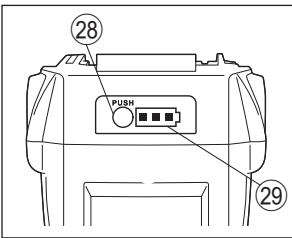

Fig.33



INSTRUCTION MANUAL AND SAFETY INSTRUCTIONS

INDEX

1. NAME OF PARTS 6

2. LIST OF CONTENTS 7

3. GENERAL POWER TOOL SAFETY WARNINGS 7

4. RB441T/RB611T SAFETY FEATURES 9

5. TOOL SPECIFICATIONS AND TECHNICAL DATA 11

6. TECHNICAL DATA 12

7. PRODUCTION YEAR 12

8. WIRE SPECIFICATION 13

9. APPLICATIONS 13

10. APPLICABLE REBAR SIZE 14

11. BATTERY INSTRUCTIONS 15

12. OPERATING INSTRUCTIONS 16

13. STORAGE AND MAINTENANCE 17

14. WARNING BUZZERS AND PROCEDURES TO FOLLOW 19

DEFINITIONS OF SIGNAL WORDS

- WARNING:** Indicates a hazardous situation which, if not avoided, could result in death or serious injury.
- CAUTION:** Indicates a hazardous situation which, if not avoided, could result in minor or moderate injury.
- NOTICE:** Indicates a property damage message.

1. NAME OF PARTS

Fig.1

- | | | |
|--------------------|-------------------|-------------------------------|
| ① Arm | ⑧ Release button | ⑮ Main switch |
| ② Trigger lock | ⑨ Release stopper | ⑯ Hook |
| ③ Trigger | ⑩ Curl guide | ⑰ Window |
| ④ Grip | ⑪ Center mark | ⑱ Feeding gear |
| ⑤ Battery pack | ⑫ Serial number | ⑲ Wire guide |
| ⑥ Magazine stopper | ⑬ Torque dial | ⑳ Belt hook (sold separately) |
| ⑦ Magazine | ⑭ LED | |

Fig.2

- ⑳ Pack cap
- ㉑ Terminal
- ㉒ Latch

Fig.3

Refer to the JC925A operating and maintenance manual.

Fig.12

- ㉔ Magazine cover

Fig.13

- ㉕ Holding slot

Fig.32







- ㉖ Sensor
- ㉗ Lens

Fig.33

- ㉘ Battery level check button
- ㉙ Battery level gauge

Symbols

The following show symbols used for the machine.

	Keep hands and body parts away from the Arm and Curl guide.		CAUTION WARNING
	UNLOCK LOCK		Read instruction manual and safety instructions before using the tool.
V	Rated volts		Do not dispose of battery packs/batteries into fire or water.
	Direct current		Protect the battery against heat, also against continuous sun irradiation and fire.

2. LIST OF CONTENTS

- MAX Rebar Tying tool / RB441T/RB611T
- Lithium ion Battery pack / JPL91450A
- Lithium ion Battery charger / JC925A
- Power cord
- INSTRUCTION MANUAL AND SAFETY INSTRUCTIONS (This book)

3. GENERAL POWER TOOL SAFETY WARNINGS

⚠ WARNING

Read all safety warnings, instructions, illustrations and specifications provided with this power tool. Failure to follow all instructions listed below may result in electric shock, fire and/or serious injury.

Save all warnings and instructions for future reference.

The term "power tool" in the warnings refers to your mains-operated (corded) power tool or battery-operated (cordless) power tool.

1. Work area safety

- **Keep work area clean and well lit.** Cluttered or dark areas invite accidents.
- **Do not operate power tools in explosive atmospheres, such as in the presence of flammable liquids, gases or dust.** Power tools create sparks which may ignite the dust or fumes.
- **Keep children and bystanders away while operating a power tool.** Distractions can cause you to lose control.

2. Electrical safety

- **Power tool plugs must match the outlet. Never modify the plug in any way. Do not use any adapter plugs with earthed (grounded) power tools.** Unmodified plugs and matching outlets will reduce risk of electric shock.
- **Avoid body contact with earthed or grounded surfaces, such as pipes, radiators, ranges and refrigerators.** There is an increased risk of electric shock if your body is earthed or grounded.

- **Do not expose power tools to rain or wet conditions.** Water entering a power tool will increase the risk of electric shock.
- **Do not abuse the cord. Never use the cord for carrying, pulling or unplugging the power tool. Keep cord away from heat, oil, sharp edges or moving parts.** Damaged or entangled cords increase the risk of electric shock.
- **When operating a power tool outdoors, use an extension cord suitable for outdoor use.** Use of a cord suitable for outdoor use reduces the risk of electric shock.
- **If operating a power tool in a damp location is unavoidable, use a residual current device (RCD) protected supply.** Use of an RCD reduces the risk of electric shock.

3. Personal safety

- **Stay alert, watch what you are doing and use common sense when operating a power tool. Do not use a power tool while you are tired or under the influence of drugs, alcohol or medication.** A moment of inattention while operating power tools may result in serious personal injury.
- **Use personal protective equipment. Always wear eye protection.** Protective equipment such as a dust mask, non-skid safety shoes, hard hat or hearing protection used for appropriate conditions will reduce personal injuries.
- **Prevent unintentional starting. Ensure the switch is in the off-position before connecting to power source and/or battery pack, picking up or carrying the tool.** Carrying power tools with your finger on the switch or energising power tools that have the switch on invites accidents.
- **Remove any adjusting key or wrench before turning the power tool on.** A wrench or a key left attached to a rotating part of the power tool may result in personal injury.
- **Do not overreach. Keep proper footing and balance at all times.** This enables better control of the power tool in unexpected situations.
- **Dress properly. Do not wear loose clothing or jewellery. Keep your hair and clothing away from moving parts.** Loose clothes, jewellery or long hair can be caught in moving parts.

- If devices are provided for the connection of dust extraction and collection facilities, ensure these are connected and properly used. Use of dust collection can reduce dust-related hazards.
 - Do not let familiarity gained from frequent use of tools allow you to become complacent and ignore tool safety principles. A careless action can cause severe injury within a fraction of a second.
4. **Power tool use and care**
- **Do not force the power tool. Use the correct power tool for your application.** The correct power tool will do the job better and safer at the rate for which it was designed.
 - **Do not use the power tool if the switch does not turn it on and off.** Any power tool that cannot be controlled with the switch is dangerous and must be repaired.
 - **Disconnect the plug from the power source and/or remove the battery pack, if detachable, from the power tool before making any adjustments, changing accessories, or storing power tools.** Such preventive safety measures reduce the risk of starting the power tool accidentally.
 - **Store idle power tools out of the reach of children and do not allow persons unfamiliar with the power tool or these instructions to operate the power tool.** Power tools are dangerous in the hands of untrained users.
 - **Maintain power tools and accessories. Check for misalignment or binding of moving parts, breakage of parts and any other condition that may affect the power tool's operation. If damaged, have the power tool repaired before use.** Many accidents are caused by poorly maintained power tools.
 - **Keep cutting tools sharp and clean.** Properly maintained cutting tools with sharp cutting edges are less likely to bind and are easier to control.
 - **Use the power tool, accessories and tool bits etc. in accordance with these instructions, taking into account the working conditions and the work to be performed.** Use of the power tool for operations different from those intended could result in a hazardous situation.
- **Keep handles and grasping surfaces dry, clean and free from oil and grease.** Slippery handles and grasping surfaces do not allow for safe handling and control of the tool in unexpected situations.
5. **Battery tool use and care**
- **Recharge only with the charger specified by the manufacturer.** A charger that is suitable for one type of battery pack may create a risk of fire when used with another battery pack.
 - **Use power tools only with specifically designated battery packs.** Use of any other battery packs may create a risk of injury and fire.
 - **When battery pack is not in use, keep it away from other metal objects, like paper clips, coins, keys, nails, screws or other small metal objects, that can make a connection from one terminal to another.** Shorting the battery terminals together may cause burns or a fire.
 - **Under abusive conditions, liquid may be ejected from the battery; avoid contact. If contact accidentally occurs, flush with water. If liquid contacts eyes, additionally seek medical help.** Liquid ejected from the battery may cause irritation or burns.
 - **Do not use a battery pack or tool that is damaged or modified.** Damaged or modified batteries may exhibit unpredictable behaviour resulting in fire, explosion or risk of injury.
 - **Do not expose a battery pack or tool to fire or excessive temperature.** Exposure to fire or temperature above 130°C may cause explosion.
 - **Follow all charging instructions and do not charge the battery pack or tool outside the temperature range specified in the instructions.** Charging improperly or at temperatures outside the specified range may damage the battery and increase the risk of fire.
6. **Service**
- **Have your power tool serviced by a qualified repair person using only identical replacement parts.** This will ensure that the safety of the power tool is maintained.
 - **Never service damaged battery packs.** Service of battery packs should only be performed by the manufacturer or authorized service providers.

4. RB441T/RB611T SAFETY FEATURES

1. INSPECT THE PARTS BEFORE MOUNTING THE BATTERY PACK

- Examine the screws to make sure they are securely tightened.
Incomplete tightening may result in an accident or breakage. If a screw is loose, retighten it completely.
- Inspect parts for damage.
Parts will wear over periods of use. Look also for missing and defective parts and for parts of poor quality. If a part must be replaced or repaired, purchase the replacement part at the dealer where the tool was purchased or MAX CO., LTD. authorized distributors.
Use only genuine authorized replacement parts.

2. SET THE MAIN SWITCH (FIG.6.⑮) AT "OFF", THE TRIGGER LOCK (FIG.6.②) AT "LOCK" AND REMOVE THE BATTERY PACK (FIG.6.⑤), WHEN CHANGING THE BATTERY PACK, REPLACING OR ADJUSTING THE TIEWIRE, ABNORMALITIES OCCUR, AND THE TOOL IS NOT BEING USED

Leaving the tool switched on in these situations may cause breakdowns or damage.

3. KEEP FINGERS AND BODY PARTS CLEAR BETWEEN THE ARM AND CURL GUIDE AT ALL TIMES (FIG.23)

Failure to do so may result in serious injury.

4. KEEP FINGERS AND BODY PARTS AWAY FROM THE TIEWIRE WHEN TOOL IS IN OPERATION

Failure to do so may result in serious injury.

5. DO NOT POINT THE TOOL AT ANYONE

Personal injury may result if the tool catches an operator or anyone working near him/her. While working with the tool, be extremely careful not to bring hands, legs, and other body parts near the arm of the tool.

6. WHEN THE TOOL IS NOT IN OPERATION KEEP YOUR FINGERS OFF THE TRIGGER

Failure to do so may cause accidental tying, leading to serious injury.

7. NEVER OPERATE THE TOOL UNDER ANY ABNORMAL CONDITION

If the tool is not in good working order, or if any abnormal condition is noticed, switch it off immediately (set the Main switch at "OFF"), lock the Trigger and have it examined and repaired.

8. AFTER BATTERY INSTALLATION IF THE TOOL OPERATES WITHOUT THE TRIGGER BEING PULLED OR THE OPERATOR NOTICES UNUSUAL HEAT, SMELL, OR SOUND, DISCONTINUE OPERATION

Failure to do so may lead to serious injury. Return to dealer for safety inspection.

9. NEVER MODIFY THE TOOL

Modifying the tool will impair performance and operating safety. Any modification may lead to serious injury and void the tool warranty.

10. HANDLE THE TOOL WITH CARE.

Dropping it or subjecting it to impact may result in breakdowns or damage.

11. MAINTAIN THE TOOL IN GOOD OPERATING CONDITION

To secure operating safety and ensure top performance, keep the tool free of wear and damage. Also keep the tool's hand grip dry and clean, especially free of oil and grease.

12. USE ONLY THE AUTHORIZED BATTERY PACK

If the tool is connected to a power supply other than the authorized pack, such as a rechargeable battery, a dry cell, or a storage battery for use in automobiles, the tool may be damaged, break down, overheat, or even catch on fire. Do not connect this tool to any power supply except the authorized battery pack.

13. TO ENSURE MAXIMUM PERFORMANCE, FULLY CHARGE THE BATTERY BEFORE USE

A new battery pack or one not used for extended periods may have self-discharged and thus may need recharging to restore it to a fully charged condition. Before operating the tool, make sure to charge the Battery pack with the designated MAX Battery charger.

14. BATTERY CHARGING PRECAUTION

- 14-1 Use only MAX Battery charger and MAX Battery pack.**
Failure to do so may cause the Battery to overheat or catch fire leading to serious injury.
- 14-2 Charge the Battery from AC between 100V and 240V wall sockets.**
Failure to do so may result in overheating, or inadequate charging possibly causing serious injury.
- 14-3 Never use a transformer.**
- 14-4 Never connect the Battery charger to an engine generator direct-current power supply.**
The charger will break down or be damaged from burning.
- 14-5 Avoid charging the Battery pack in the rain, in a damp place, or where water is splashing.**
Charging a damp or wet Battery pack will cause an electric shock or a short circuit that may lead to damage from burning and even the tool catching on fire.
- 14-6 Do not touch the power cord or plug with a wet hand or glove.**
This may cause injury from electric shock.
- 14-7 Do not put a cloth or any other cover on the Battery charger while the Battery pack is being charged.**
This will cause overheating and damage from burning, or the Charger may even catch fire.
- 14-8 Keep the Battery pack and Battery charger away from heat and flames.**
- 14-9 Do not charge the Battery pack near flammable materials.**
- 14-10 Charge the Battery pack in a well ventilated place.**
Avoid charging the Battery pack where it will be in direct sunlight.
- 14-11 Charge the Battery pack in a temperature range of 5°C (41°F) to 40°C (104°F).**
- 14-12 Avoid continual use of the Battery charger.**
Rest the Charger for 15 minutes between charges to avoid functional trouble with the unit.
- 14-13 Any objects that block the ventilation holes or Battery pack receptacle may cause electric shock or functional troubles.**

Operate the charger free of dust or other foreign materials.

- 14-14 Handle the power cord carefully.**
Do not carry the Battery charger by its power cord. Do not use the power cord to disconnect it from a wall socket; this will damage the cord and break the wires or cause a short circuit. Do not let the power cord contact sharp edged tools, hot materials, oil, or grease. A damaged cord must be repaired or replaced.
- 14-15 Do not charge non rechargeable batteries with this charger.**
- 14-16 This charger is not intended for use by children or disabled persons without supervisor.**
- 14-17 Children should be supervised to ensure that they do not play with the charger.**
- 14-18 Put a Pack cap (Fig.2.21) on the Terminal (Fig.2.22) of the Battery pack.**
When the Battery pack is not in use, put a Pack cap on its Terminal to prevent short circuits.
- 14-19 Do not let the Terminal (metal component) of the Battery pack short-circuit.**
A short circuit in the Terminal will generate a large current, causing to overheat the Battery pack and become damaged.
- 14-20 Do not leave or store the tool in a vehicle or in direct sunlight during summer. Leaving the tool in high temperature conditions may cause the Battery pack to deteriorate.**
- 14-21 Do not store a fully discharged Battery pack. If a fully discharged Battery pack is removed from the system and left for a long period of time, it may become damaged. Recharge the battery immediately when it has been discharged.**

15. WEAR SAFETY GLOVES WHILE OPERATING THE TOOL

The finish tie has sharp edges. To avoid serious injuries, be careful not to touch the sharp edges.

16. PRIOR TO USING THE TOOL

(Fig.4 and 5) Make sure that the safety features function properly. If they do not, avoid using the tool.

5. TOOL SPECIFICATIONS AND TECHNICAL DATA

PRODUCT DESCRIPTION	MAX Rebar Tying tool "TWINTIER"	
PRODUCT NO.	RB441T(CE)	RB611T(CE)
DIMENSIONS (Battery pack included)	(H) 295mm (11-1/2") (W) 120mm (4-5/8") (L) 330mm (13")	(H) 300mm (11-7/8") (W) 120mm (4-5/8") (L) 350mm (13-7/8")
WEIGHT (Battery pack included)	2.5kg / 5.6lbs	2.5kg (5.6lbs)
BATTERY	Lithium ion Battery pack / JPL91450A	
OPERATING TEMPERATURE	-10°C to 40°C (14°F to 104°F)	
HUMIDITY	80% RH or less	

<BATTERY CHARGER>

PRODUCT DESCRIPTION	Lithium ion Battery charger
MODEL	JC925A
INPUT	AC100 - 240V 50/60Hz 2.2A
OUTPUT	DC14.4V: 4.0A, DC18V: 4.0A, DC25.2V: 2.8A
WEIGHT	0.7kg (1.7lbs)
OPERATING TEMPERATURE RANGE	5°C to 40°C (41°F to 104°F)
OPERATING HUMIDITY RANGE	80% RH or less

<BATTERY PACK>

PRODUCT DESCRIPTION	Lithium ion Battery pack
MODEL	JPL91450A
NOMINAL VOLTAGE	DC14.4V(3.6V x 4cells)
NOMINAL CAPACITY	4.9Ah (4,900mAh)
CHARGING TIME	Full charging 80min. Approx. 80% of capacity 60min
ACCESSORIES	Pack cap
WEIGHT	0.5kg (1.1lbs)
CHARGING TEMPERATURE	5°C to 40°C (41°F to 104°F)
OPERATING TEMPERATURE RANGE	0°C to 40°C (32°F to 104°F)
OPERATING HUMIDITY RANGE	80% RH or less

TIES PER CHARGE (*under the following conditions: normal temperature, unused, full-charged battery)	Approx. 5,000 ties
--	--------------------

Do not use the power tool in the rain, where water is splashing, in a wet place, or in a damp place. Using the tool in these or similar conditions will increase the risk of electric shock, dangerous malfunction, and overheating.

Do not dispose of power tools into household waste. According to the European Guideline 2002/96/EC for Waste Electrical and Electronic Equipment and its implementation into national right, power tools that are no longer usable must be collected separately and disposed of in an environmentally correct manner.

8. WIRE SPECIFICATION

TIEWIRE			TW1061T	TW1061T-PC	TW1061T-EG	TW1061T-S
TYPE OF WIRE			Annealed wire	Poly-coated wire	Electro-galvanized wire	Stainless wire
DIAMETER			1.0mm	1.1mm	1.0mm	1.0mm
TIES/COIL	RB441T	10 mm × 10 mm (#3 × #3)	Approx. 265 ties	Approx. 230 ties	Approx. 265 ties	Approx. 265 ties
		13 mm × 13 mm (#4 × #4)	Approx. 240 ties	Approx. 210 ties	Approx. 240 ties	Approx. 240 ties
		22 mm × 16 mm × 16 mm (#7 × #5 × #5)	Approx. 170 ties	Approx. 150 ties	Approx. 170 ties	Approx. 170 ties
	RB611T	16 mm × 16 mm (#5 × #5)	Approx. 205 ties	Approx. 170 ties	Approx. 205 ties	Approx. 205 ties
		22 mm × 22 mm (#7 × #7)	Approx. 170 ties	Approx. 145 ties	Approx. 170 ties	Approx. 170 ties
		38 mm × 16 mm (#12 × #5)	Approx. 150 ties	Approx. 125 ties	Approx. 150 ties	Approx. 150 ties
		38 mm × 16 mm × 16 mm (#12 × #5 × #5)	Approx. 140 ties	Approx. 115 ties	Approx. 140 ties	Approx. 140 ties

• RB441T/RB611T is not compatible with TW898 series or TW1525 series.

9. APPLICATIONS

- Precast concrete panel
- Building foundation
- Commercial building
- Road & Bridge
- Floor heating pipe

10.APPLICABLE REBAR SIZE

■ 2 rebars combination

		Minimum	Maximum
	RB441T	10mm × 10mm (#3 × #3)	22mm × 22mm (#7 × #7) 25mm × 19mm (#8 × #6)
	RB611T	16mm × 16mm (#5 × #5)	32mm × 29mm (#10 × #9) 41mm × 19mm (#13 × #6)

■ 3 rebars combination

		Minimum	Maximum
	RB441T	10mm × 10mm × 10mm (#3 × #3 × #3)	22mm × 16mm × 16mm (#7 × #5 × #5) 25mm × 13mm × 13mm (#8 × #4 × #4)
	RB611T	10mm × 10mm × 10mm (#3 × #3 × #3)	38mm × 16mm × 16mm (#12 × #5 × #5)





■ 4 rebars combination

		Minimum	Maximum
	RB441T	10mm × 10mm × 10mm × 10mm (#3 × #3 × #3 × #3)	16mm × 16mm × 13mm × 13mm (#5 × #5 × #4 × #4)
	RB611T	10mm × 10mm × 10mm × 10mm (#3 × #3 × #3 × #3)	19mm × 19mm × 19mm × 19mm (#6 × #6 × #6 × #6)

11. BATTERY INSTRUCTIONS

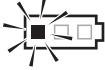
About the Battery Level Indicator

- (1) To check the battery level (excluding while charging or while operating the charging tool), press the Battery level check button (Fig.33.⑳).
- (2) The Battery level gauge (Fig.33.㉑) is on according to the battery level.

	Battery level: 0%	Battery level: about 0 to 10%	Battery level: about 10 to 40%	Battery level: about 40 to 70%	Battery level: about 70 to 100%
Battery level gauge					
	All indicators OFF	One red indicator blinks	One red indicator ON	Two red indicators ON	Three red indicators ON

Service Life of the Battery pack

If any condition described below is observed, the Battery pack is at the end of its service life. Replace it with a new one.

Although the Battery pack has been properly charged (fully charged), a great drop in tying time has been noticed.

NOTICE

- Do not charge the Battery pack when this happens. If the motor's rotational speed slows down, the power of the Battery pack is considered to be nearly depleted. Using the tool more will cause it to overdischarge, resulting in a shortened service life of the Battery pack and also in functional trouble of the tool's main body.
- Do not use a Battery pack when its service life is finished.
- This will cause functional trouble in the tool's main body. Also charging a Battery pack that is out of service life will lead to functional trouble in the Charger.
- Do not dispose of battery packs/batteries into fire or water. Battery packs/batteries should be collected, recycled or disposed of in an environmental-friendly manner.
- Protect the battery against heat, also against continuous sun irradiation and fire. There is danger of explosion.
- Charge the battery pack in a temperature range 5°C (41°F) to 40°C (104°F).

Recycling a Li-ion Battery

Defective or dead out battery packs/batteries must be recycled according to the guideline 2006/66/EC. The MAX battery pack uses a Li-ion battery, it may be illegal to dispose of this Battery into the municipal waste system. Check with your local solid waste officials for details in your area for recycling options or proper disposal.



CAUTION

When disposing of the Battery pack, make sure to put a Pack cap on its Terminal (with insulating tape securing it) to prevent short circuits.

12. OPERATING INSTRUCTIONS

1. How to set the Tiewire

(Fig.6) Set the Main switch (15) at "OFF", the Trigger lock (2) at "LOCK" and remove the Battery pack (5).



CAUTION

- Be careful not to drop or give a strong impact to the Tiewire. It may cause the damage and the malfunction of the tool.
- Beware of the tip of the wire when you pick up the Tiewire. It might cause an injury.

1-1 (Fig.9) Press the Release button (8) of this tool, and confirm that the Release button is caught in the Release stopper (9).

1-2 (Fig.10) Stretch out the tip of the wound Tiewire.

BE SURE TO USE ONLY THE SPECIFIED TIEWIRE (MAX TW1061T Series).

The use of binding wire that has not been specified may cause breakdown of this tool. Therefore, be sure only to use the specified MAX TW1061T series.

RB441T, RB611T is not compatible with TW898 series or TW1525 series.

DO NOT USE RUSTY WIRE.

The use of the rusty wire may cause functional trouble of the tool.

1-3 (Fig.11) Rotate the Magazine stopper (6) 45° counterclockwise.

1-4 (Fig.12,13) Open the Magazine cover (24) and set the Tiewire in the Magazine (7) with the Holding slot (25) side of the reel facing up.

1-5 (Fig.14) Grasp the tool with the left hand, hold the tip of the wire with the right hand, and remove the wire from the Holding slot.

NOTICE

The 2 wire tips of new Tiewire are twisted.

1-6 (Fig.15) Straighten out the tip of the wire, and insert the twisted wire into the Wire guide (19) parallel.

1-7 (Fig.16) Confirm through the Window that the twisted part of wire has reached past two Feeding gears (18).

1-8 (Fig.17) Press the Release stopper (9) up, and confirm that the Release button has been raised up.

1-9 (Fig.18) Close the Magazine cover and rotate the Magazine stopper 45° clockwise.

If the Window is dirty

Open the Window (Fig.1.17) and wipe off the dirt on the inside of the Window with a cloth. Close the Window again after cleaning to ensure that foreign objects will not be able to enter the tool.

2. How to operate RB441T/RB611T

(Fig.6) Set the Main switch (15) at "OFF", the Trigger lock (2) at "LOCK" and remove the Battery pack (5).

2-1 (Fig.19) Mount the Battery pack on the tool's main body until a click is heard.

2-2 (Fig.20) When Main switch (15) is turned "ON", the Hook (Fig.1.16) of the tip rotates automatically for initializing, absolutely do not bring your fingers close to any rotating and moving part. Set the Main

switch at "ON" and the trigger lock (②) at "UNLOCK".

- 2-3 (Fig.21) Tilt the tool 45° angle to the crossed rebars.
- 2-4 (Fig.22) Align the Center mark (⑪) to the center of the crossed rebars.
- 2-5 Once pull the Trigger, the tool automatically completes a series of tying actions (feeding, cutting, gripping and tying).



WARNING

- (Fig.23) When the Main switch (Fig.1.⑮) is turned "ON", the Hook (Fig.1.⑩) of the tip rotates automatically for initialization, absolutely do not bring your fingers close to any rotating and moving part.
- Do not touch any rotating and moving part such as hook of the tip or the Tiewire during the tying work (while the machine is operating).

3. How to remove the Tiewire

(Fig.6) Set the Main switch (⑮) at "OFF", the Trigger lock (②) at "LOCK" and remove the Battery pack (⑤).

- 3-1 (Fig.9) Press the Release button (⑧) of the tool and confirm that the Release button is caught in the Release stopper (⑨).
- 3-2 (Fig.11) Rotate the Magazine stopper (⑥) to open the Magazine cover.
- 3-3 (Fig.24) Remove the Tiewire from the Magazine.
- 3-4 (Fig.25) Remove the wire with the plastic piece from the Wire guide.

4. When the Tiewire runs out

(Fig.26) The plastic piece comes off when it is used up normally, and can be discarded separately as plastic and metal wire. (About 20 cm remains after normal use)

(Fig.6) Set the Main switch (⑮) at "OFF", the Trigger lock (②) at "LOCK" and remove the Battery pack (⑤).

5. Tension adjustment

(Fig.27.⑬) This dial allows you to adjust wire tension torque slightly. To increase the tension, turn it in the counterclockwise. To decrease the tension, turn it in the clockwise.

6. Auto Power-off feature

This tool has "Auto Power-off" feature, which saves the power consumption of the Battery when the tool is not operated.

If the tool is not operated for 30 minutes, the tool is automatically turned off. When the power is turned off automatically, turn the Main switch OFF and ON again to operate the tool.

7. For proper tightness

- 7-1 (Fig. 21) Tilt the tool 45° angle to the crossed rebars.
- 7-2 (Fig.22) Align the Center mark (⑪) to the center of the crossed rebars.
- 7-3 (Fig.28) Apply the tool perpendicularly to the surface of the crossed rebars.

During tool operation

Do not move the tool during tying operation until the tool stops tying automatically.

- 7-4 (Fig.29) Tie in alternate direction.
- 7-5 (Fig.30) Cross tying.
Bent the knot of the first tie before making the second tying.

8. How to reload previously used Tiewire

(Fig.31) Without twisting the 2 wires, insert them into the Wire guide (⑲).

13.STORAGE AND MAINTENANCE

Do not store the tool in a cold weather environment. Keep the tool in a warm area. When not in use, the tool should be stored in a warm and dry place. Keep out of reach of children.

REMOVE REEL OF TIEWIRE

When you have finished the Tiewire, remove the reel from the tool.

STORE THE TOOL

When you have finished tying work or when the tool will not be used for a while, set the Main switch (Fig.1.⑮) at "OFF", the Trigger lock (Fig.1.②) at "LOCK" and remove the Battery pack (Fig.1.⑤). The tool and accessories should be stored in a well-ventilated dry place where the temperature will not exceed 40°C (104°F).

The Battery pack with the Pack cap (Fig.2.⑳) to prevent short circuits should be stored in a well-ventilated dry place where the temperature will not exceed 30°C (86°F).

MAINTENANCE

Do not blow air around Feeding gears (Fig.1.⑱) and Hooks (Fig.1.⑲).

Dust can enter the inside of a machine and cause malfunctions.

When three short beeps are repeated, dust the sides of sensors (Fig.32.㉔) and the top of lenses (Fig.32.㉕) with a soft cloth or cotton bud gently.

Wipe the tool with a soft dry cloth.

Do not use a wet cloth or volatile substances such as thinner or benzine.

Do not lubricate the equipment

Absolutely do not lubricate this equipment.

Applying lubrication will remove the grease inside of the tool, and cause problem on the tool.

14. WARNING BUZZERS AND PROCEDURES TO FOLLOW

This tool sounds warning buzzers for the conditions described below. If the buzzer sounds, follow procedures according to the conditions described below.



WARNING

- If the conditions described below occur, set the Main switch (Fig.1.⑮) at "OFF", the Trigger lock (Fig.1.②) at "LOCK" and remove the Battery pack (Fig.1.⑤) before following procedures.
- Do not touch the tying or rotating parts at the tip when setting the Main switch at "ON" under any circumstances.

<Buzzer types and procedures to follow>

Buzzer types	Possible cause	Procedures to follow
Once (Pi, pi, pi...)	Wire is jammed in the Hook (Fig.1.⑯)	Check whether the wire or anything else is caught in the Hook
	Motor is hot	Let the tool rest and cool down
Twice (Pipi, pipi, pipi...)	Low battery	Charge the Battery pack
	Battery pack is not fully inserted	Insert the Battery pack properly
Three times (Pipipi, pipipi, pipipi...)	Tiewire is used up	Replace with a new Tiewire
	Tiewire is jammed	Open the Magazine cover (Fig.12.⑳) and fix the jammed wire
	Dust the sensor in Magazine.	Dust the sides of sensors and lenses with water or cotton bud gently.
Continuous high pitched beep (Piii...)	Curl guide (Fig.1.⑩) is open (RB441T)	Confirm supported rebar diameters
Continuous high & low pitched chime (Pii poh Pii poh...)	Internal structure; defect in internal driving mechanism	Immediately discontinue operation and set the Main switch (Fig.6.⑮) at "OFF", the Trigger lock (Fig.6.②) at "LOCK" and remove the Battery pack (Fig.6.⑤) before consulting. Then contact the dealer where the tool was purchased or MAX CO., LTD. authorized distributors.
Single-short beep (Popi)		

<When no buzzer sounds but malfunction is suspected>

Symptom	Possible cause	Procedures to follow
Main switch is "ON" but does not work	Dead battery	Switch to a new battery and confirm whether it works
Product does not function	Auto Power-off feature operated	Try switching the Main switch (Fig.1.⑮) from OFF to ON
Tying is not proper	Wire is touching rebars while tying	Tie so that wire is not touching rebars
Twisted off	Rebar size is not applicable	Use with supported rebars diameters
	Tension adjustment dial is too tight	Adjust tension adjustment dial (Fig.1.⑬)
Tension is too loose	The tied section is not on the Center mark (Fig.22.⑪)	Align the Center mark to the center of the crossed rebars and pull the trigger
	Rebar size is not applicable	Use with supported rebar diameters
	Tension adjustment dial is too loose	Adjust tension adjustment dial tighter (Fig.1.⑬)
Tie form is notably deformed	Worn or broken parts	Immediately discontinue operation and set the Main switch (Fig.6.⑮) at "OFF", the Trigger lock (Fig.6.②) at "LOCK" and remove the Battery pack (Fig.6.⑤) before consulting. Then contact the dealer where the tool was purchased or MAX CO., LTD. authorized distributors.
Increased frequency of jamming		

RB441T(CE)/RB611T(CE)

EU DECLARATION OF CONFORMITY

We hereby declare that the following our product conforms to protection of health and safety of persons, and protection of the environment.

Product (Apparatus)	Re-Bar Tying Tool
Model	RB441T/RB611T
Manufacturer	6-6 NIHONBASHI HAKOZAKI-CHO, CHUO-KU, TOKYO, JAPAN
Authorized Compiler in the community	MAX EUROPE B.V. Antennestraat 45, 1322 AH, Almere, The Netherlands

This declaration of conformity is issued under the sole responsibility of the above manufacturer.

The object of declaration described above is in conformity with the EU harmonisation legislation below.

Machinery Directive	2006/42/EC EN ISO 12100:2010 EN62841-1:2015
EMC Directive	2014/30/EU EN 61000-6-4:2007+A1:2011/EN IEC 61000-6-2:2019 EN 61000-4-2:2009/EN 61000-4-3:2006+A1:2008+A2:2010 EN 61000-4-8:2010
RoHS Directive	2015/863/EU

Noise Emission in the Environment by Equipment for Use Outdoors Directive 2000/14/EC

Title	Senior Manager Environment & Quality Assurance Department
-------	--

Being the responsible person appointed by the manufacturer and employed by MAX CO., LTD.

RB441T(CE)/RB611T(CE)

UK DECLARATION OF CONFORMITY

We hereby declare that the following our product conform to protection of health and safety of persons, and protection of the environment.

Product(Apparatus)	Re-Bar Tying Tool
Model	RB441T/RB611T
Manufacturer	MAX CO., LTD. 6-6 NIHONBASHI HAKOZAKI-CHO, CHUO-KU, TOKYO, JAPAN

This declaration of conformity is issued under the sole responsibility of the above manufacturer.

The object of declaration described above is in conformity with the UK Legislation below.

- The Supply of Machinery (Safety) Regulations 2008
EN ISO 12100:2010
EN 62841-1: 2015
Safety requirement for Electric Motor-Operated Hand-Held Tools, Transportable Tools and Lawn and Garden Machinery
- Electromagnetic Compatibility Regulations 2016
EN 61000-6-4:2007+A1:2011
EN IEC 61000-6-2:2019
EN 61000-4-2:2009
EN 61000-4-3:2006+A1:2008+A2:2010
EN 61000-4-8:2010
- The Restriction of the Use of Certain Hazardous Substances in Electrical and Electronic Equipment Regulations 2012

Title : Senior Manager
Environment & Quality Assurance Department

Being the responsible person appointed by the manufacturer and employed by MAX CO., LTD.

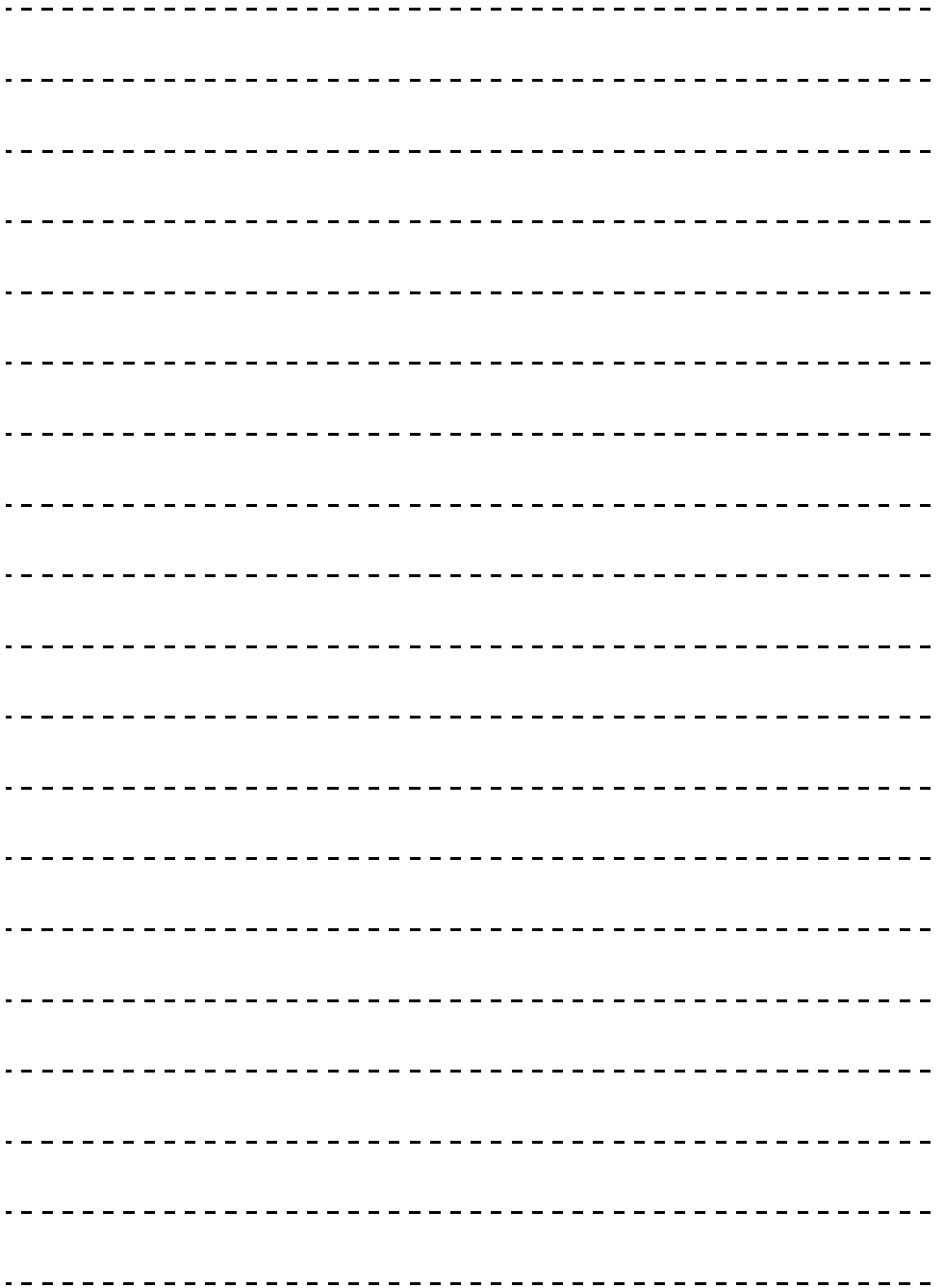

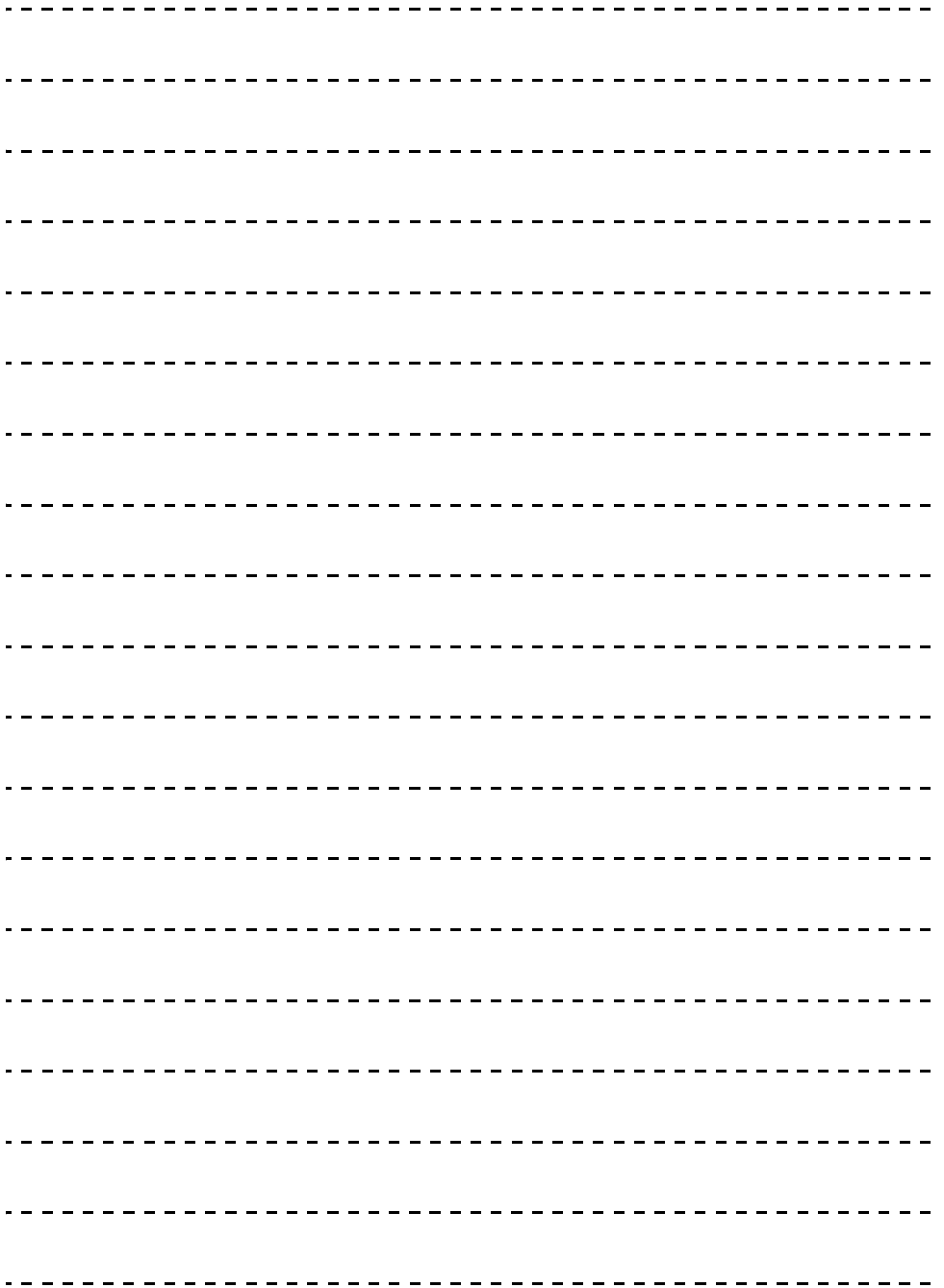

- The content of this manual might be changed without notice for improvement.



MAX CO., LTD.

MAX EUROPE B.V.

Antennestraat 45,
1322 AH, Almere, The Netherlands
Phone: +31-36-546-9669
FAX: +31-36-536-3985
sales@max-europe.com
www.max-europe.com

